

C. B. VAN COUGHNET.
MECHANICAL MOVING POWER.

No. 483,881.

Patented Oct. 4, 1892.

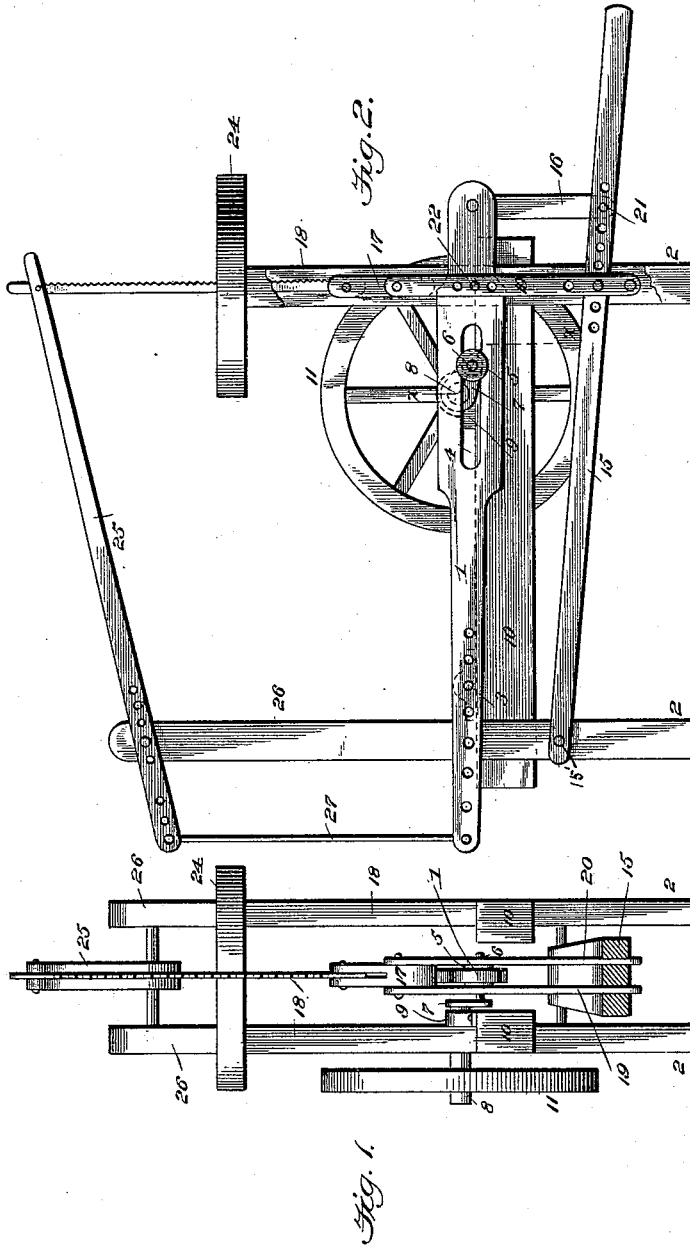

Witnesses:
W. C. Schiele
Arthur L. Bryant

Inventor:
C. B. Van Coughnet
 By *Edson Bros*,
 Attys.

C. B. VAN COUGHNET.
MECHANICAL MOVING POWER.

No. 483,881.

Patented Oct. 4, 1892.

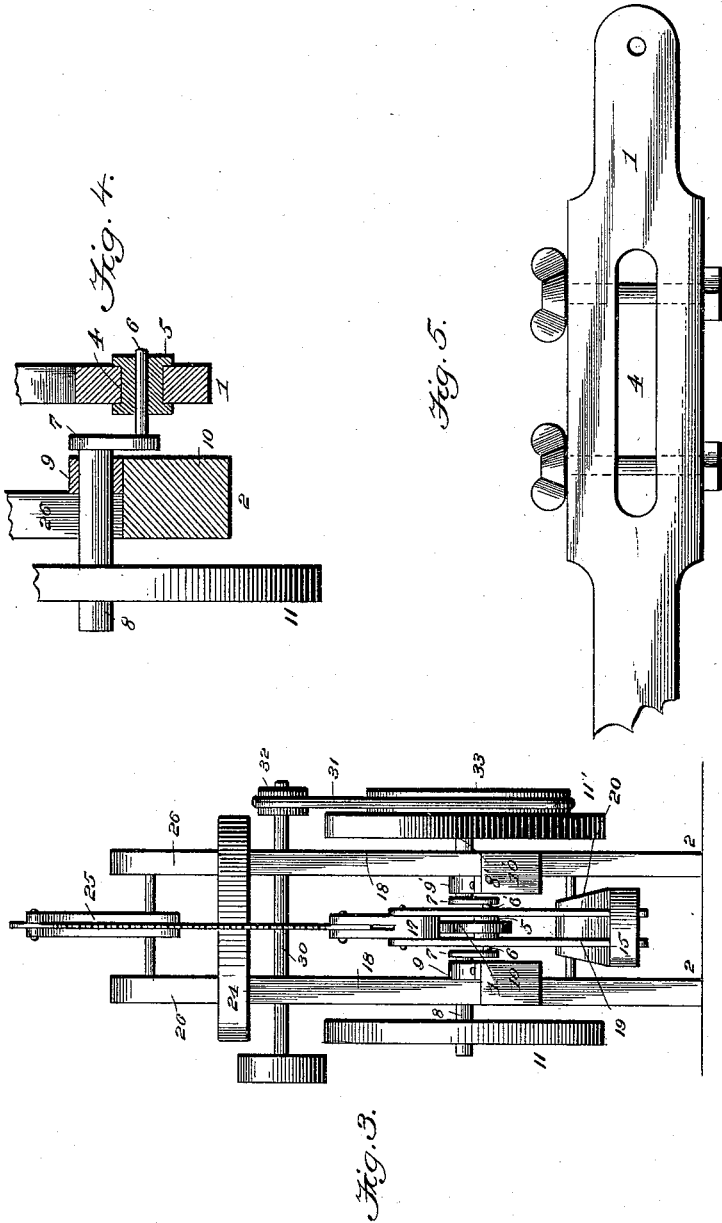

Witnesses
Wm. C. ...
Arthur L. ...

Inventor
 C. B. Van Coughnet
 By *Edmond Bros.*
 Att'ys.

UNITED STATES PATENT OFFICE.

CHARLES B. VAN COUGHNET, OF WATERTOWN, NEW YORK.

MECHANICAL MOVING-POWER.

SPECIFICATION forming part of Letters Patent No. 483,881, dated October 4, 1892.

Application filed February 19, 1892. Serial No. 422,120. (No model.)

To all whom it may concern:

Be it known that I, CHARLES B. VAN COUGHNET, a citizen of the United States, residing at Watertown, in the county of Jefferson and State of New York, have invented certain new and useful Improvements in Mechanical Moving-Powers; and I do hereby declare the following to be a full, clear, and exact description of the invention, such as will enable others skilled in the art to which it appertains to make and use the same.

My invention relates to improvements in mechanical moving-powers; and it has for its object to reduce the friction on the parts of the power and to provide a simple, light-running, and inexpensive power for running a lathe, sewing-machine, scroll-sawing machine, or any other light-power machine.

With these ends in view and such others as pertain to my invention it consists in the combination of devices and peculiar construction and arrangement of parts, which will be hereinafter fully described and claimed.

To enable others to understand my invention, I will now proceed to a detailed description thereof in connection with the accompanying drawings, in which—

Figure I is a front elevation of a mechanical moving power embodying my invention, showing a single driving-shaft and fly-wheel. Fig. II is a side elevation thereof. Fig. III is an end elevation of another form of my invention in which I employ two aligned driving-shafts on opposite sides of the main lever and a corresponding number of fly-wheels. Fig. IV is an enlarged sectional view on the line *x x* of Fig. II. Fig. V is a detail sectional view of the slotted end of the main lever.

Like numerals of reference denote corresponding parts in all the drawings, in which—

1 designates the main operating-lever of the motor, which is fulcrumed near its front end to the main frame 2 of a power constructed in accordance with my invention. This main lever has a series of apertures at its front end, in one of which is fitted an arbor or pin 3, which is suitably supported in the frame, and the rear end of this lever has a longitudinal slot 4. In this slot of the lever operates a friction-roller 5, which is fitted loosely on and carried by a crank-pin 6, rigidly

affixed to a crank-arm 7, as shown in Fig. I; or said crank-pin may be rigidly secured at both ends to two crank-arms 6 6', as shown in Fig. III.

If desired, the slotted end 4 of the main lever may be provided with bolts, as shown in Fig. V, to tighten the sides of the lever on the crank-pin 6 when necessary, said bolts passing through each end of the slot. The single crank-arm is carried by a driving-shaft 8, which is journaled in a suitable bearing 9, rigidly affixed to one of the longitudinal sills 10 of the main frame, and the outer end of this driving-shaft carries a single fly or balance wheel 11, whereby the motion of the shaft is rendered more uniform and steady.

The slotted main lever 1 of my improved motor is arranged in the longitudinal center of the main frame, and the driving-shaft, its crank-arm, and the balance-wheels are all arranged at one side of said lever and supported on one of the sills of said frame. This driving-shaft may, however, be duplicated, as indicated in Fig. III of the drawings, in which figure the numeral 6' designates the crank-arm on the second driving-shaft 8', which is journaled in a separate bearing 9', fixed on the other sill 10' of the frame, the outer end of the duplicate shaft 8' being provided with a balance-wheel 11'.

In the arrangement shown in Fig. III the crank-pin extends through the slot in the main lever and is united to the two crank-arms, so as to connect or join the same, and by this peculiar organization of parts and the provision of the friction-roller which works freely on the crank-pin and in the slot of the lever I am enabled to provide a very light-running power which operates very steadily and uniformly and with very little friction on its parts.

The main lever may be operated by any suitable power; but in the drawings I have shown said main lever as adapted to be operated by foot-power, which is applied to the machine through the medium of a treadle 15, pivoted at its forward end to the main frame, as at 15'. This treadle is connected at a point intermediate of its length directly to the main lever by means of a link 16, and said treadle is further connected with a reciprocating head-block 17 by the means which I

will now describe. The head-block 17 is located above the main lever, between upright standards 18 of the main frame, and to opposite sides of this head-block are rigidly fixed depending arms 19 20, which embrace opposite sides of the main lever and extend to the treadle. Said arms are pivoted at their lower ends to the treadle, as at 21, and to the main lever at intermediate points of their length, as at 22, and at their points of connection with said treadle and lever the arms and the parts are perforated, as shown, to provide for the necessary adjustment of the head-block.

In the drawings I have illustrated my power as adapted for use on a reciprocating tool—such as a scroll-saw—and in this embodiment of my invention I provide a saw-table 24 and an arm 25. This arm is pivoted near one end to uprights 26 of the main frame, the arm and the main lever being connected together by links 27, and to the free end of this pivoted arm and the reciprocating cross-head are connected the ends of the reciprocating tool or saw; but it is obvious that any kind of a reciprocating tool can be used in the machine and that various appliances can be employed to convert the reciprocating motion of the main lever into rotary motion in order to communicate the power to a sewing-machine, lathe, or other light-running machine.

As one means of communicating rotary motion to a machine from the power of my invention I may employ a counter-shaft 30, which is suitably arranged with relation to one or both of the driving-shafts, and this counter-shaft is belted to one or both of said driving-shafts by an endless band 31, which passes over a grooved pulley 32 on the counter-shaft and another pulley 33 on one of the driving-shafts.

The motor may be built as a part of a sewing-machine or lathe and the motion communicated by gearing from the counter-shaft to the lathe or machine, or the motor may be built separate from the lathe and the two machines be suitably belted or geared together.

The operation of my invention will be readily understood from the foregoing description, taken in connection with the drawings.

Having thus fully described my invention, what I claim as new, and desire to secure by Letters Patent, is—

1. In a mechanical moving-power, the combination of a main lever fulcrumed on a suitable frame and provided with a longitudinal slot at an intermediate point of its length, the driving-shafts arranged in axial alignment with each other and provided on their approximate inner ends with the aligned crank-arms, the crank-pin connecting the free ends of said crank-arms and extending through the slot in the main lever, the loose friction-roller on said crank-pin and riding on the walls of the slot in the main lever, a treadle, and the links connecting the main lever and the treadle, substantially as described.

2. In a mechanical moving-power, the combination of the main lever having the longitudinal slot 4, the driving-shaft, the crank-arm on said shaft and having its crank-pin provided with a friction-roller that rides in the slot of the main lever, the head-block 17, links connecting the head-block, the treadle, and the main lever, the arm 25, linked to the main lever, and the counter-shaft geared to the driving-shaft, substantially as described.

In testimony whereof I affix my signature in presence of two witnesses.

CHAS. B. VAN COUGHNET.

Witnesses:

GEO. H. COBB,
PETER J. QUINN.